

PROUDLY AUSTRALIAN

ELPHINSTONE

WEIGHING SYSTEMS
LOGGING TRAILERS

Elphinstone Engineering Aust. Pty. Ltd. ACN 009 533 984

Trading as: **Elphinstone Engineering**

Victoria

PH. (03) 9311 6366

FAX. (03) 9311 6466

E-mail: vic.office@elph.com.au

Head Office

PH. (03) 6257 3242

FAX. (03) 6257 3573

E-mail: tri.office@elph.com.au

Western Australia

PH. (08) 9734 3820

FAX. (08) 9734 2795

E-mail: wa.office@elph.com.au

Internet Site: www.elph.com.au

Elphinstone Engineering's **Hydraulic Fold A Skel**

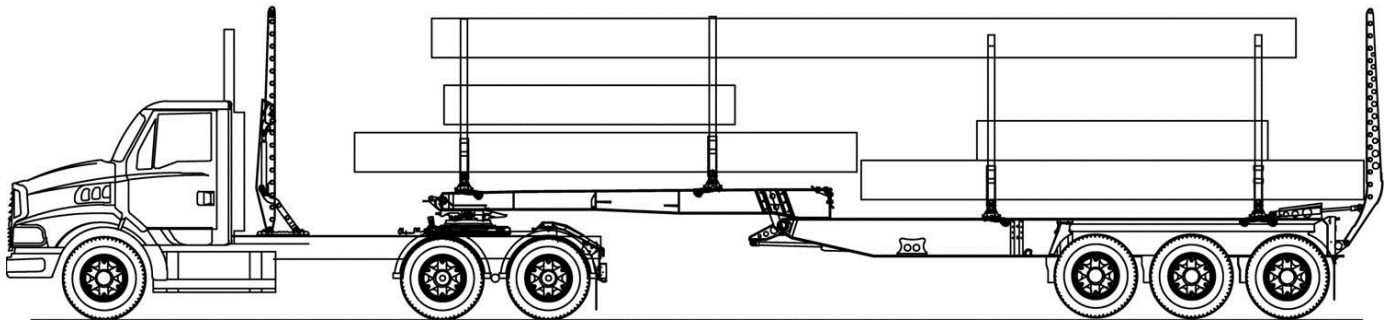
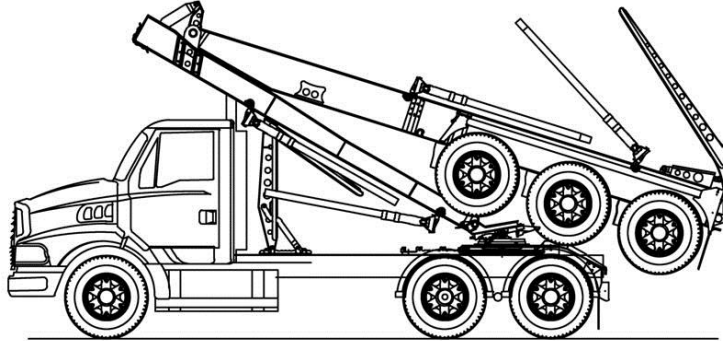

Features and Advantages of Elphinstone's Hydraulic Fold A Skel

- Single action folding.
- Single switch operation.
- Fully bolted frame.
- Low centre of gravity for good stability.
- Wide variety of load lengths.
- Optional rear guard.
- Standard quick release.
- Controls and hydraulic system fitted in truck are the same as for "Easyloader".

Ref: H:\elph.com.au\00 HTML\downloads\brochures\hydraulic_fold_a_skel.doc

Manufacturers and Installers of Elphinstone

On-Vehicle and Stationary Weighing Systems, Logging Trailers and Equipment since 1976