

PRODUCT APPLICATION

ON-VEHICLE WEIGHING SYSTEM

Suit Side Loader Waste Compactor



- u **Protect yourself against overload fines and accident liability**
- u Weigh entire payload
- u Accuracy guaranteed +/- 1%
- u Load to the maximum payload every load
- u Simple installation during manufacture
- u Mounting kits designed for easy fitting
- u Proven reliability in the waste collection industry
- u Rugged Loadcell design proven over 28 years in the logging industry
- u Simple electronics. Designed and built in Australia
- u Self diagnostics for easy troubleshooting
- u Excellent backup and after sales service
- u Lower maintenance costs
- u *Options* / *Cab mounted printer*
- / *DataLogger*
- / *Direct communication with onboard computers*
- / *Easyweigh® radio remote readout*
- / *Scoreboard display*

Proven Performance. Elphinstone have been designing and installing on-vehicle weighing systems for over 20 years. We have incorporated the latest technology to assure you of dependable service from our systems.

PROVEN UNDER AUSTRALIAN CONDITIONS FOR OVER 20 YEARS

Specifications

- LAYOUT ⇒ See Drawing Below
- CAPACITY ⇒ 6 Point – 27,000kg
⇒ 4 Point – 18,000 kg
- POWER ⇒ 12vdc (24vdc with power reducer)
- MOUNTING ⇒ Flexible mounting design to reduce stress on Truck chassis and Compactor Body

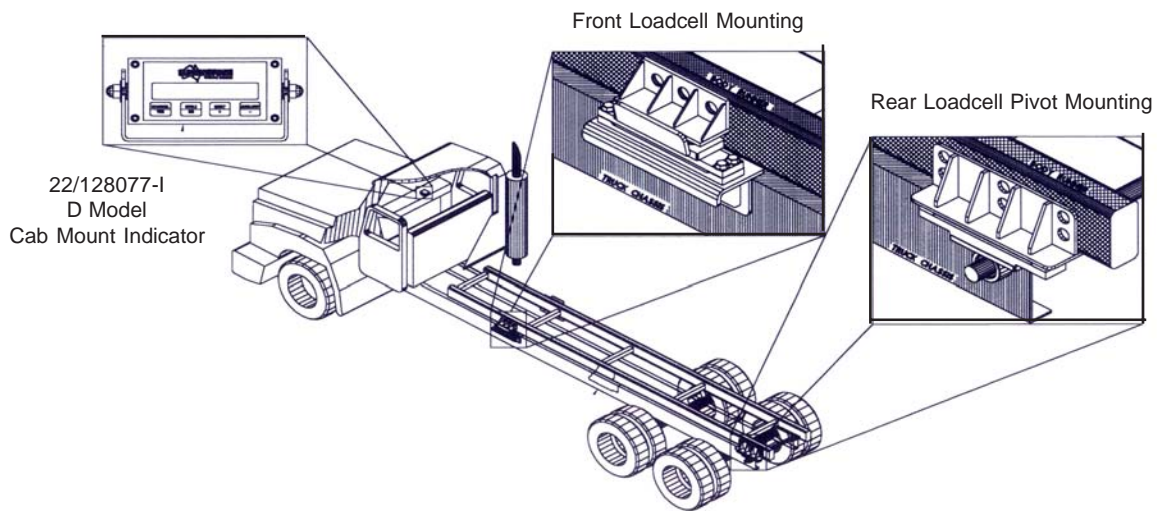

Electronics Options



Elphinstone D Model
(Cab Mount Indicator)



Elphinstone Easyweigh®
(Radio Remote Indicator)



Elphinstone L5500
(Cab Mounted Printer)

Specifications subject to change without notice

Ordering Information



Victorian Office

2/670 Somerville Road
Sunshine VIC 3020

Ph. 03 9311 6366 Fax 03 9311 6466

Email: grant@elph.com.au