

PROUDLY AUSTRALIAN

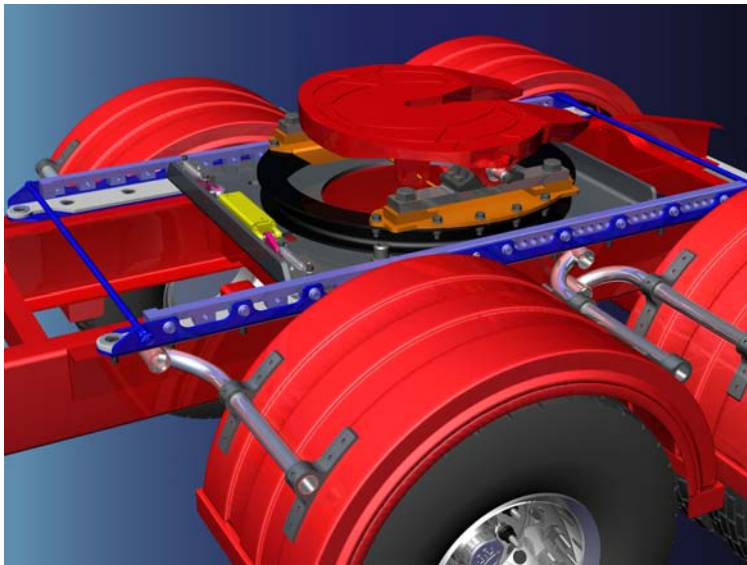

PRODUCT SPECIFICATION

ELPHINSTONE TURNTABLE SLIDER

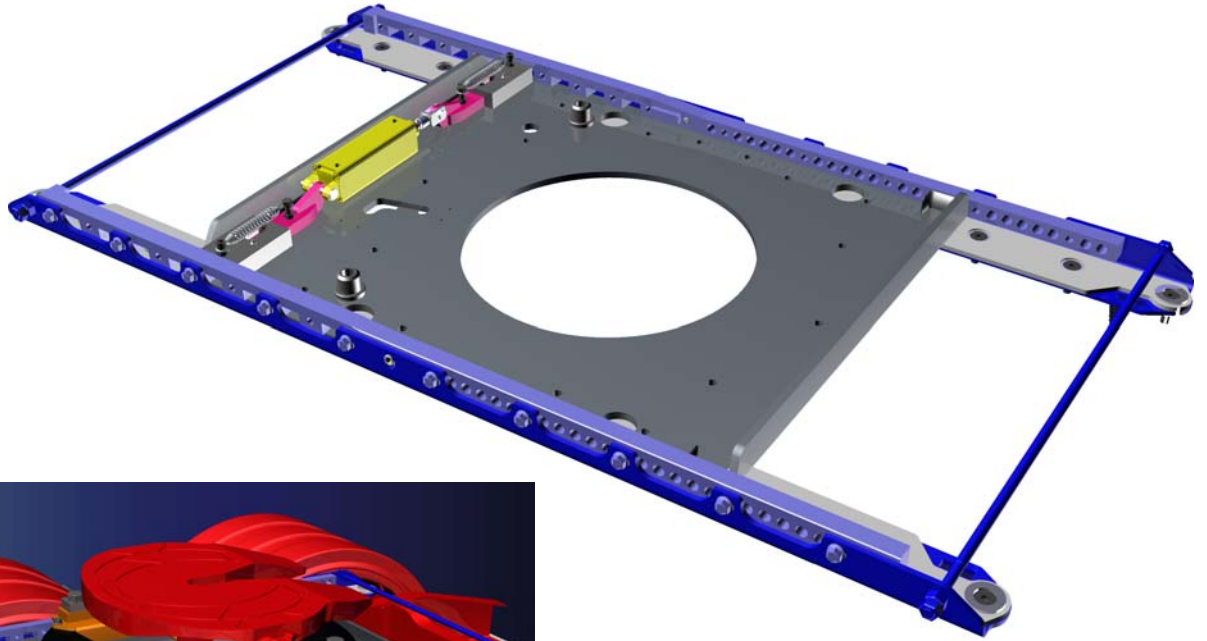

Features:

- Light Tare Weight - From 229kg
- Low Height - 20mm
- D-Rated to 200kN
- Spring loaded safety lock
- Can be moved when fully laden
- 700mm of Travel
- Replaceable Nylon Slides
- Proven Design over Millions of Kilometres
- Models to Suit All Trucks
- Pre-Assembled and Adjusted

Options:

- Drill Pattern to Suit Different Width Chassis
- Solenoid or Direct Air Activation Valves
- Ballrace or Fixed Turntable
- Loadcells with Trunnions to Suit Most Turntables
- Suits low height or standard ballraces

Specifications Subject to change without notice. These specifications supersede all previous specifications as of February 2008

Exploded View

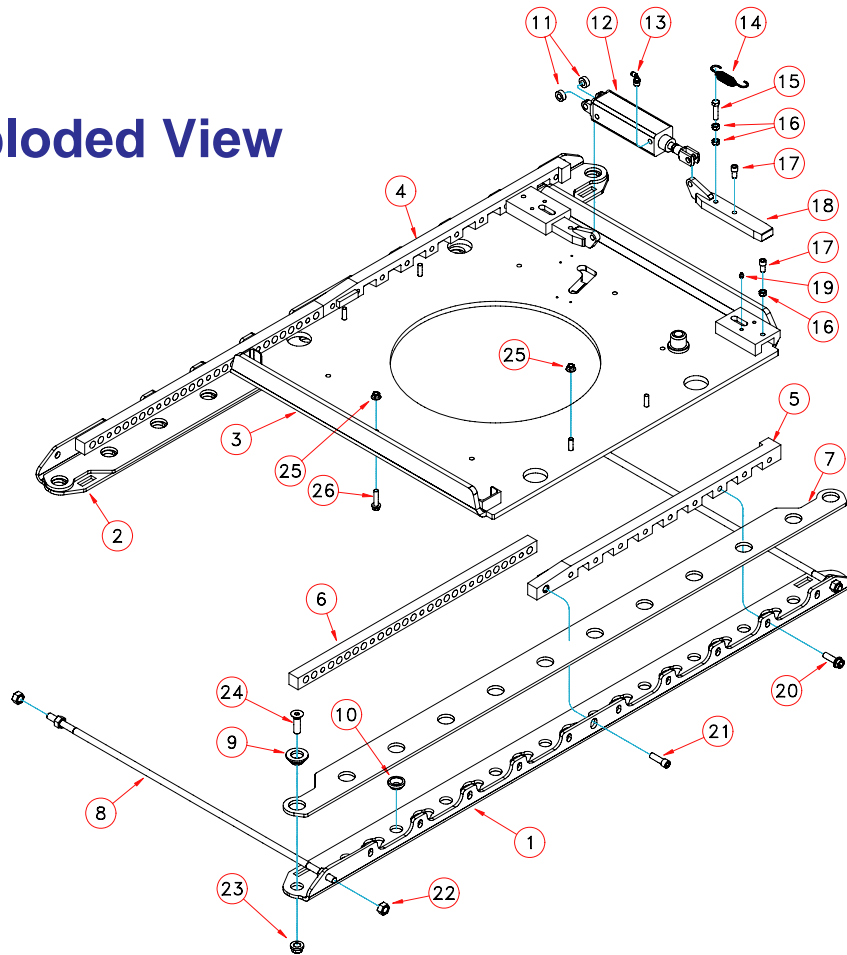

Victorian Office
 2/670 Somerville Road
 Sunshine, VIC 3020
 Ph: (03) 9311 6366
 Fax: (03) 9311 6466
 Email: vic.office@elph.com.au

Head Office
 Tasman Hwy,
 Triabunna, TAS 7190
 Ph: (03) 6257 3242
 Fax: (03) 6257 3573
 Email: tri.office@elph.com.au

WA Office
 16 Williams Road,
 Collie, WA 6225
 Ph: (08) 9734 3820
 Fax: (08) 9734 2795
 Email: wa.office@elph.com.au