

PROUDLY AUSTRALIAN

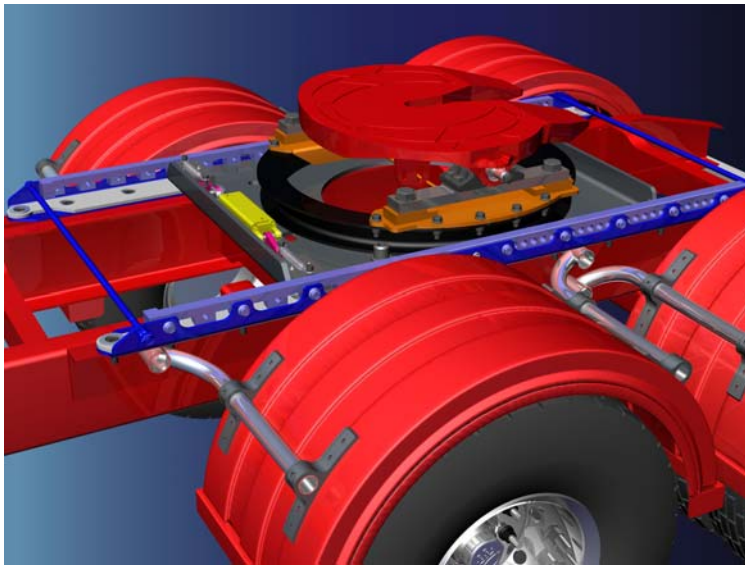

## PRODUCT SPECIFICATION

# ELPHINSTONE TURNTABLE SLIDER 2007 Model

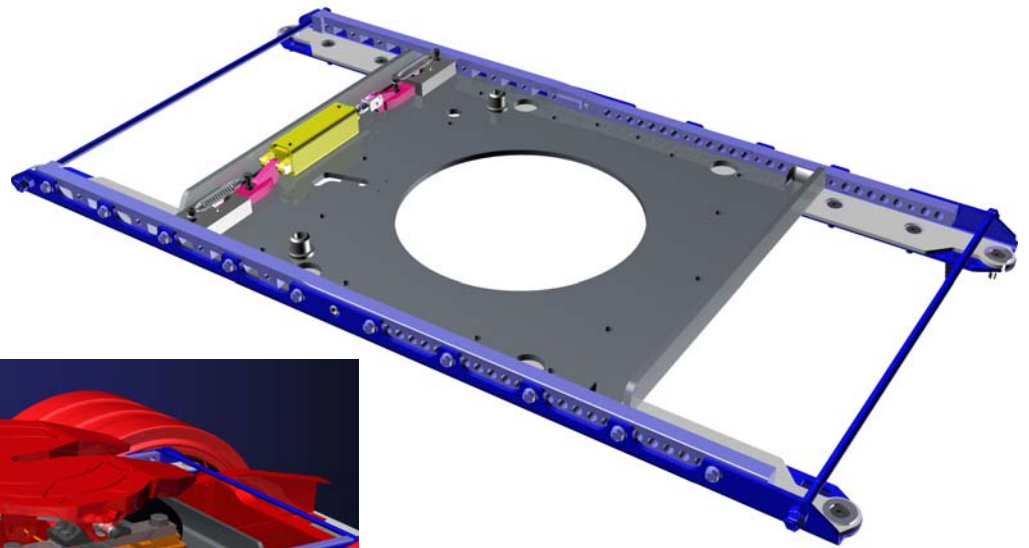

### Features:

- Light Tare Weight - From 229kg
- Low Height - 20mm
- D-Rated to 240kN
- Spring loaded safety lock
- Can be moved when fully laden
- 700mm of Travel
- Replaceable Nylon Slides
- Proven Design over Millions of Kilometres
- Models to Suit All Trucks
- Pre-Assembled and Adjusted

### Options:

- Drill Pattern to Suit Different Width Chassis
- Solenoid or Direct Air Activation Valves
- Ballrace or Fixed Turntable
- Loadcells with Trunnions to Suit Most Turntables
- Suits low height or standard ballraces

Specifications Subject to change without notice. These specifications supersede all previous specifications as of September 2006

# Exploded View

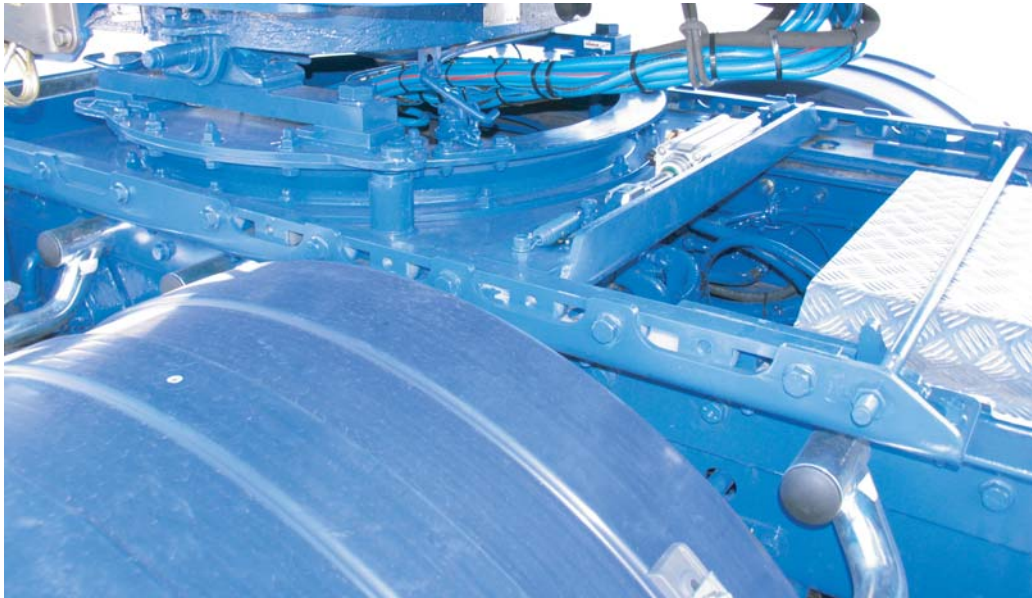
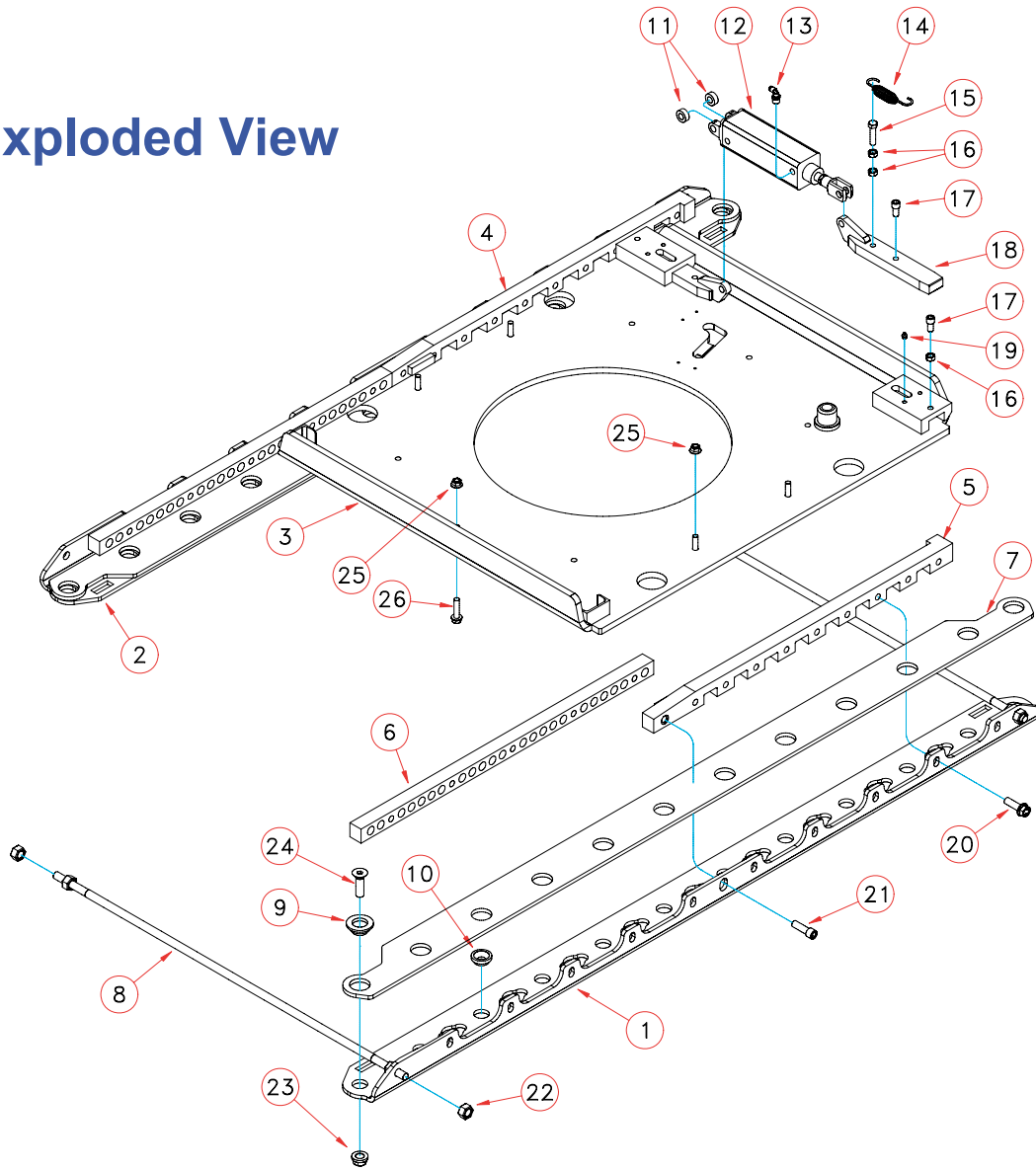

**Victorian Office**  
 2/670 Somerville Road  
 Sunshine, VIC 3020  
 Ph: (03) 9311 6366  
 Fax: (03) 9311 6466  
 Email: vic.office@elph.com.au

**NSW Office**  
 PO Box 319,  
 Riverwood, NSW 2210  
 Ph: (02) 9584 8550  
 Fax: (02) 9584 8551  
 Email: nsw.office@elph.com.au

**WA Office**  
 16 Williams Road,  
 Collie, WA 6225  
 Ph: (08) 9734 3820  
 Fax: (08) 9734 2795  
 Email: wa.office@elph.com.au

**Head Office**  
 Tasman Hwy,  
 Triabunna, TAS 7190  
 Ph: (03) 6257 3242  
 Fax: (03) 6257 3573  
 Email: tri.office@elph.com.au